

No.	NAME
①	FRESH WATER TANK
②	AIR FILTER FOR TURBO.
③	STARTING MOTOR
④	FUEL OIL FILTER
⑤	LUB OIL FILTER
⑥	F. O. INJ. PUMP & GOVERNOR

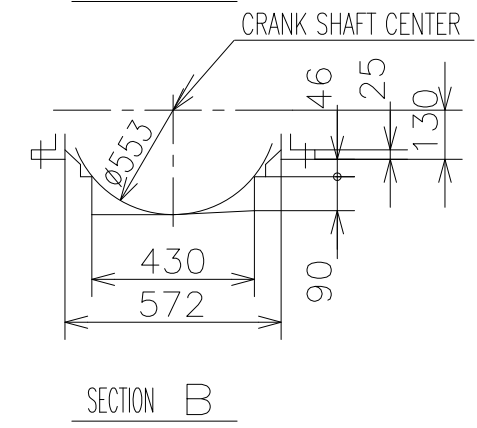
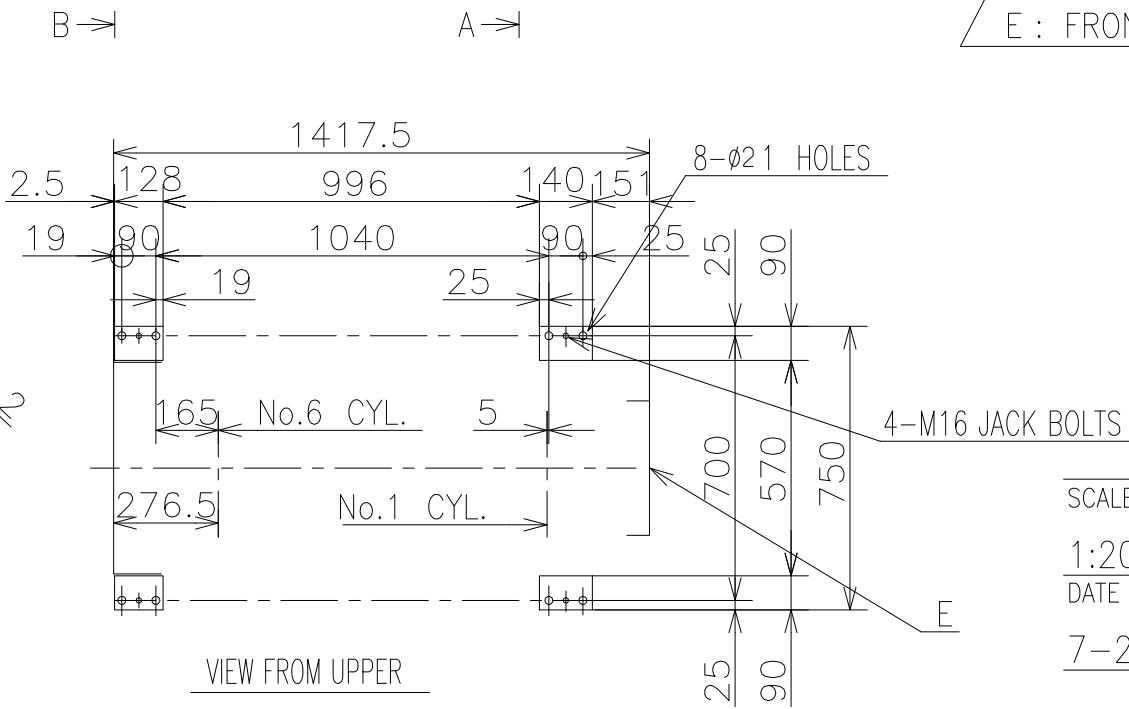
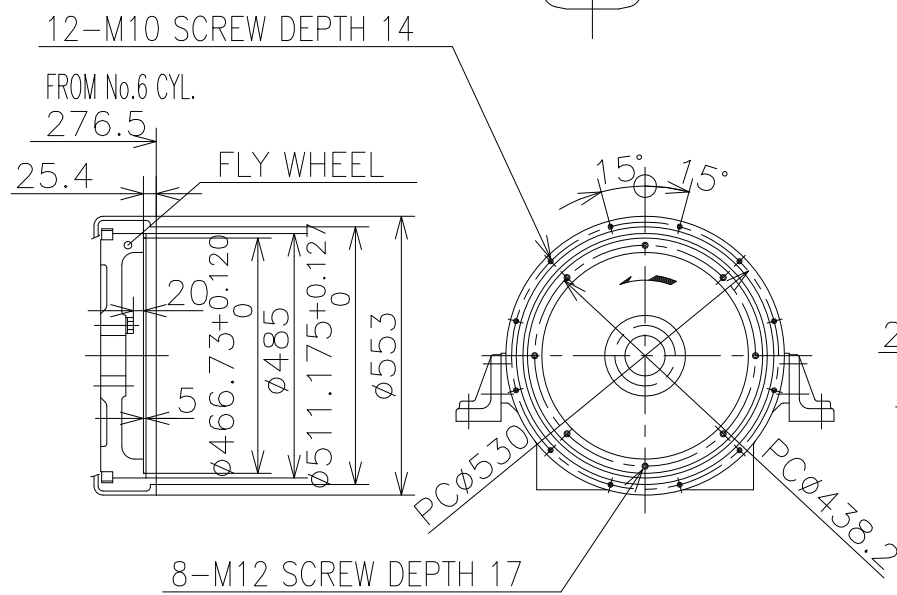
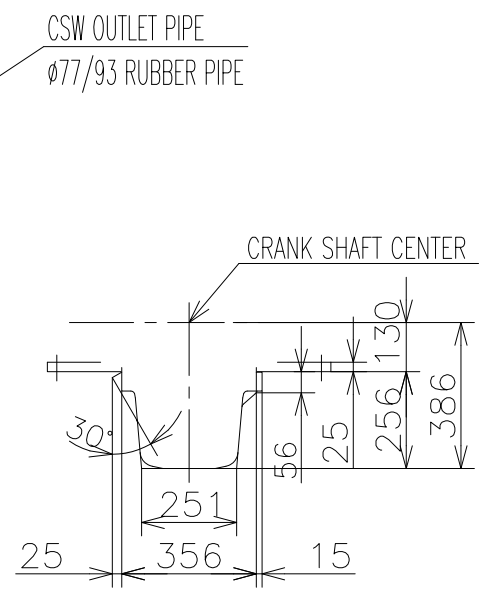
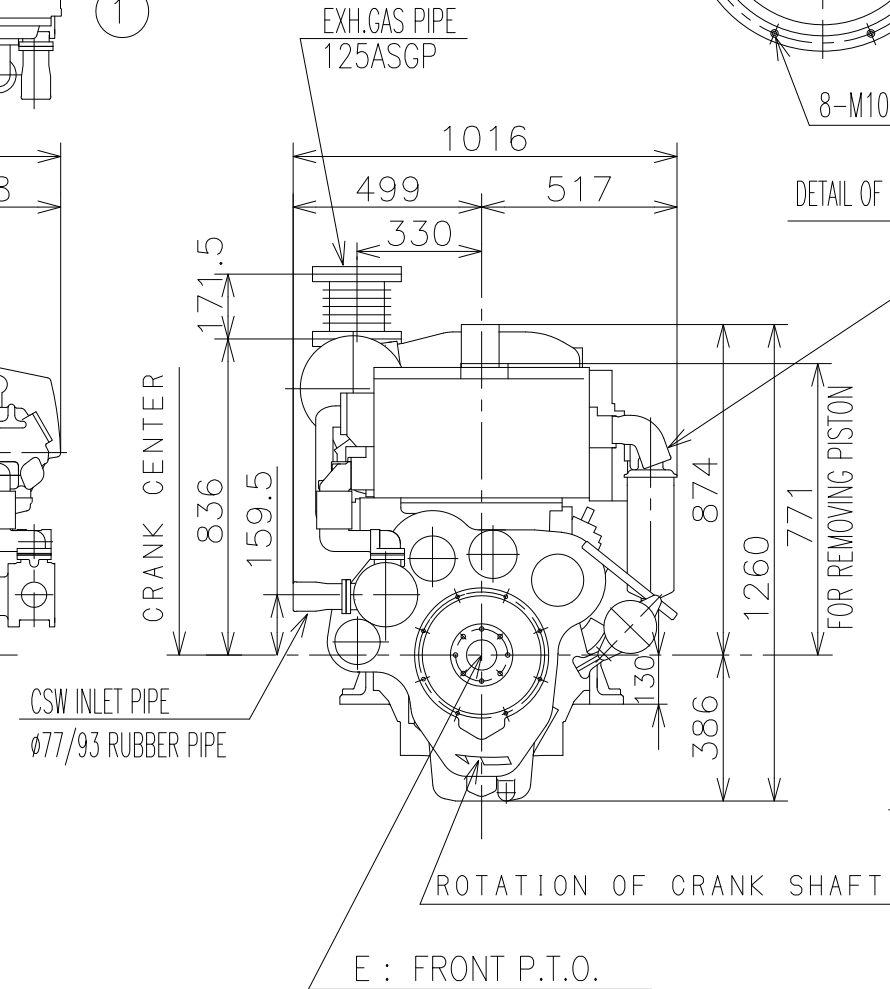
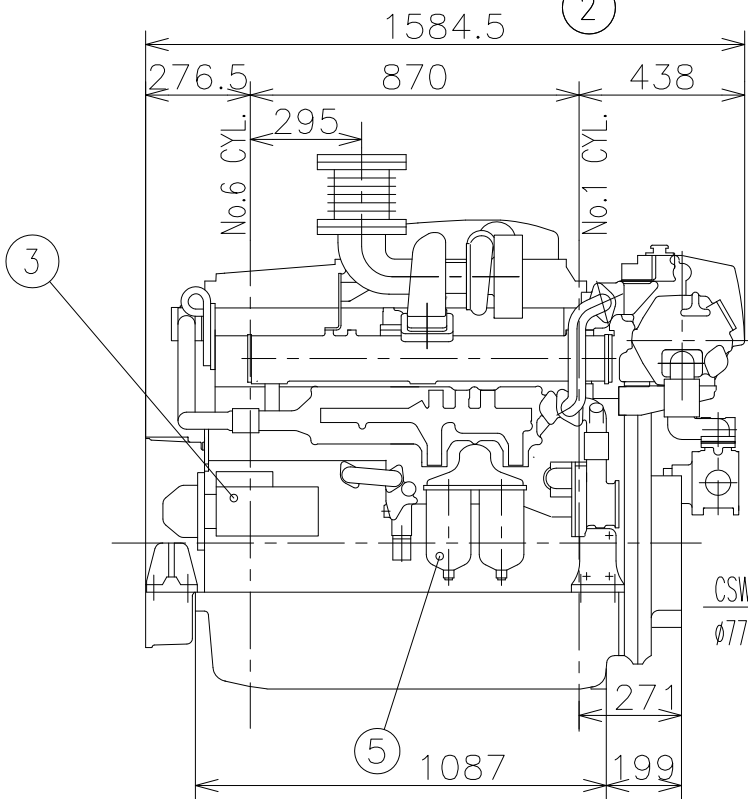
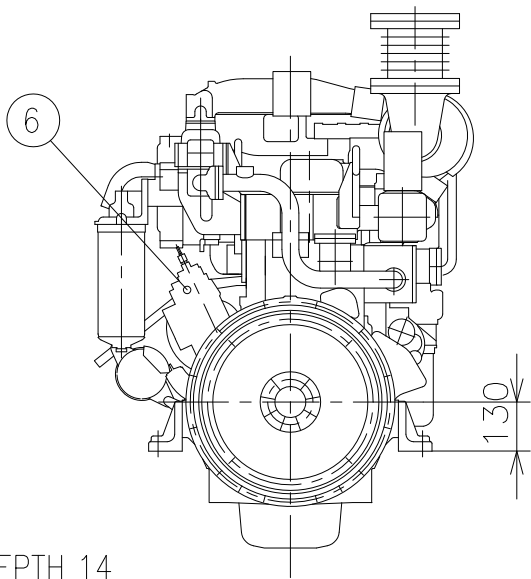
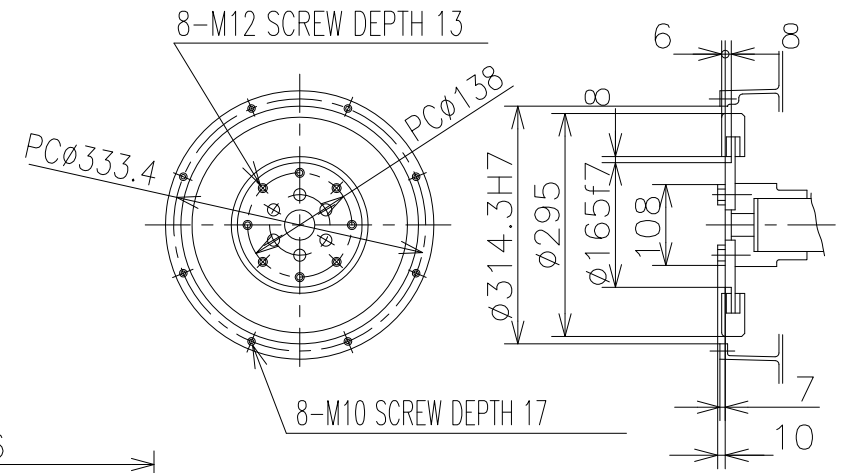
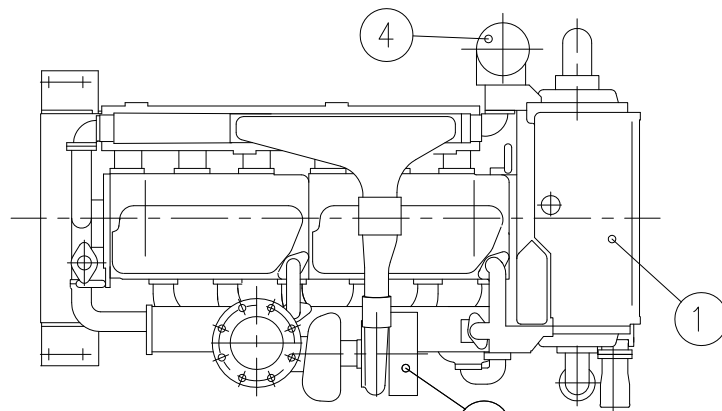

ENG. MODEL	CLUTCH MODEL
6HA2M-HTE 6HA2M-WHT	—
TOTAL MASS(abt.)	1340kg

DETAIL OF REAR P.T.O.
(S:1/15)

SCALE	NAME	MODEL
1:20(1:10,1:15)	OUTLINE	6HA2M-HTE,6HA2M-WHT
DATE	ORIGINAL DRAWING NUMBER	REVISION
7-23-1999	B3-26671-0060	0

