

DETAIL OF COUPLING

DIRECTION OF ROTATION

DETAIL OF MOUNTING BLOCK

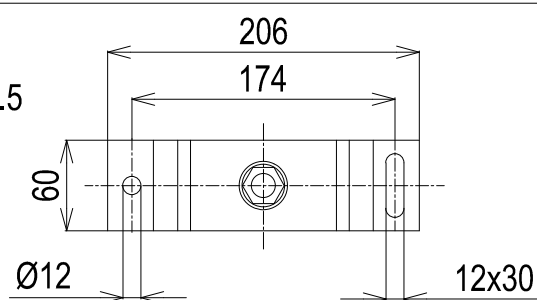
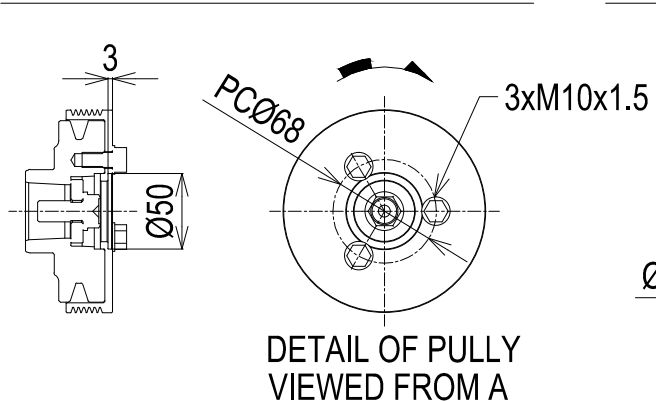
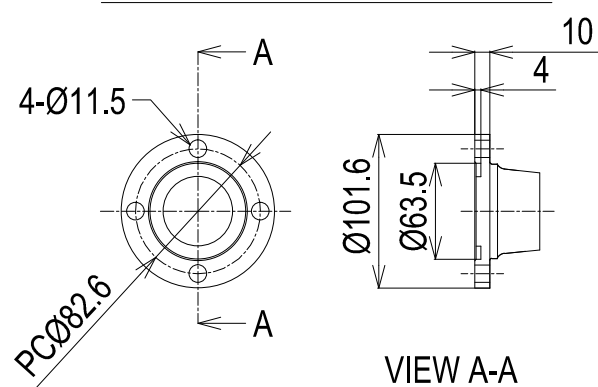

NOTE:

1. DWG. SHOWS MOUNTING BLOCKS AT ORIGINAL HEIGHT. ENGINE WEIGHT WILL COMPRESS BLOCKS BY 4MM (APPROX).
2. MOUNTING BLOCKS ARE EQUIPPED FOR STANDARD ACCESSORY.
3. ● SHOWS THE CENTER OF GRAVITY.
4. THE FIGURES MARKED WITH * SHOW THE DIMENSIONS WITH U-MIXING ELBOW, OR OPTIONAL COUPLING.
5. FOR ADDITIONAL INSTALLATION INFORMATION AND SPECIFICATIONS PLEASE REFER TO THE YANMAR ENGINE INSTALLATION MANUAL

Engine: 4JH4-HTE_ZF25A

Release: 26-11-2012

Scale: 1:10

Date: 01-06-2013

Dimensions: mm

