

☒ 面 来 歴
CAREER

(4. Apr. '02)
ADD 4LHA-STZP AND CHANGE
THE DRAWING CODE

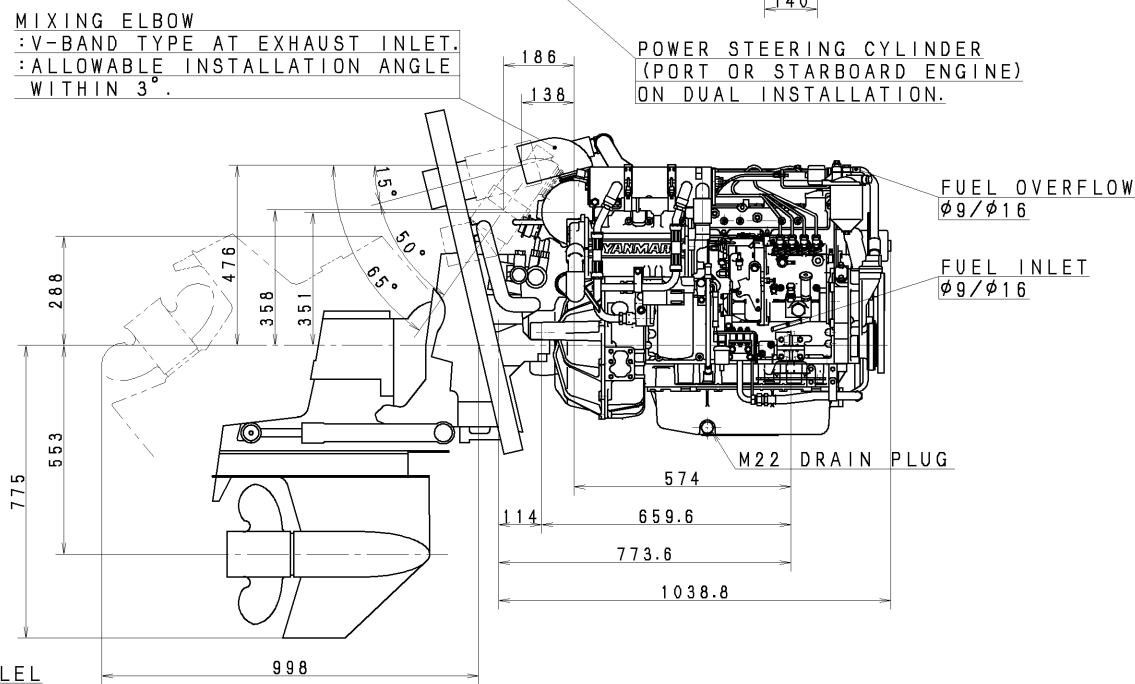
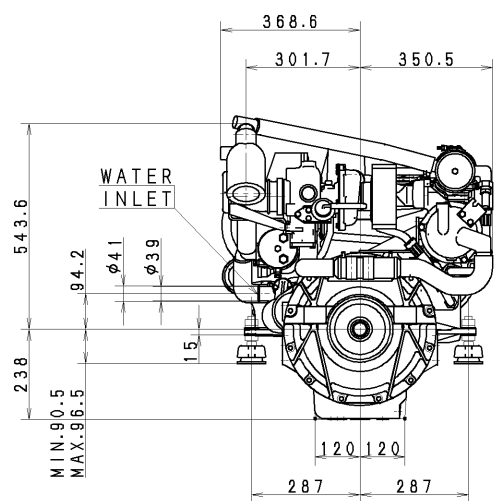

- NOTE:
1. INNER AND OUTER TRANSOM SURFACE MUST BE PARALLEL WITHIN 3mm IN AREA OF COVERED BY TRANSOM PLATES AND REMAIN WITHIN TRANSOM THICKNESS LIMITS.
 2. DWG. SHOWS MOUNTING BLOCKS AT COMPRESSED HEIGHT. (COMPRESSED BY APPROX. 3MM)
 3. AREA COVERED BY GIMBAL HOUSING ASSEMBLY MUST BE FLAT TO WITHIN 1.6mm
 4. AREA COVERED BY INNER TRANSOM PLATE MUST BE FLAT TO WITHIN 3.2mm.
 5. TRANSOM ANGLE : 13° to 16°
 6. DWG. SHOWS MOUNTING BLOCKS AT COMPRESSED HEIGHT. (FRONT:COMPRESSED BY APPROX. 3MM REAR:COMPRESSED BY APPROX. 0.6MM)

- NOTE
- DWG. SHOWS MOUNTING BLOCKS AT COMPRESSED HEIGHT. (COMPRESSED BY APPROX. 3MM)

SPECIFICATIONS			
MODEL	4LHA-STZE 4LHA-STZP		
CONT. RAITING OUTPUT (FLYWHEEL OUTPUT)	kW/rpm	140/3100	
	HP/rpm	190/3100	
MAX OUTPUT (FLYWHEEL OUTPUT)	kW/rpm	169/3300	177/3300
	HP/rpm	230/3300	240/3300
DRY WEIGHT (EXCEPT DRIVE, TRANSOM)	kg (lb)	APPROX. 385 (849)	
REDUCTION RATIO (BRAVO 1)		1.36	1.50 1.65
DIRECTION OF PROP. SHAFT ROTATION		COUNTER-CLOCKWISE	

主 席 S. Kishida	長 SEC. MANAGER S. Nakamura	機 種 MODEL	4LHA - 4LHA - STZE STZP	尺 度 SCALE	1 : 10
検 査 CHECKED S. Nakamura	審 査 担 当 者 SPECIALIST	個 数 QTY.	-	材 質 MATERIAL	-
設 計 DESIGNED T. Nakamura	製 図 DRAWN S. Nakamura	年 月 日 DATE 2002 4. 5	名 称 NAME 4LHA-STZE 4LHA-STZP X OUTLINE	カ イ ケ イ ス	
YANMAR DIESEL ENGINE CO., LTD.			コード CODE	B2-19175-0371	A2 (C)
POWER SYSTEM OPERATIONS DIV.					

汎 用 工 務 発 部
部 長
G. MANAGER
技 術 部 長
MANAGER
Y. Yamashita