

CAREER

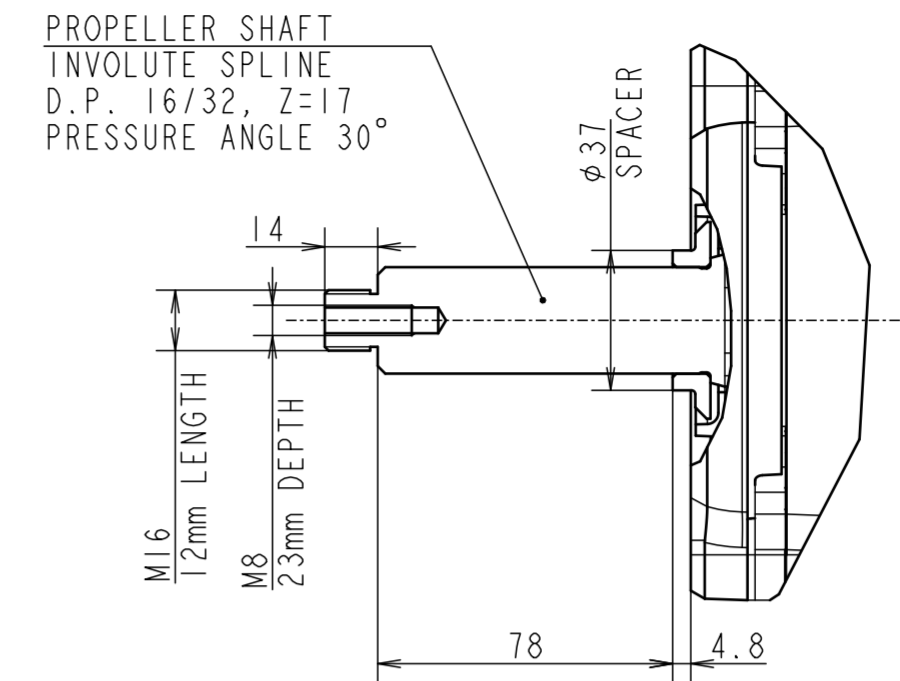

PROPELLER SHAFT (NOT TO SCALE)

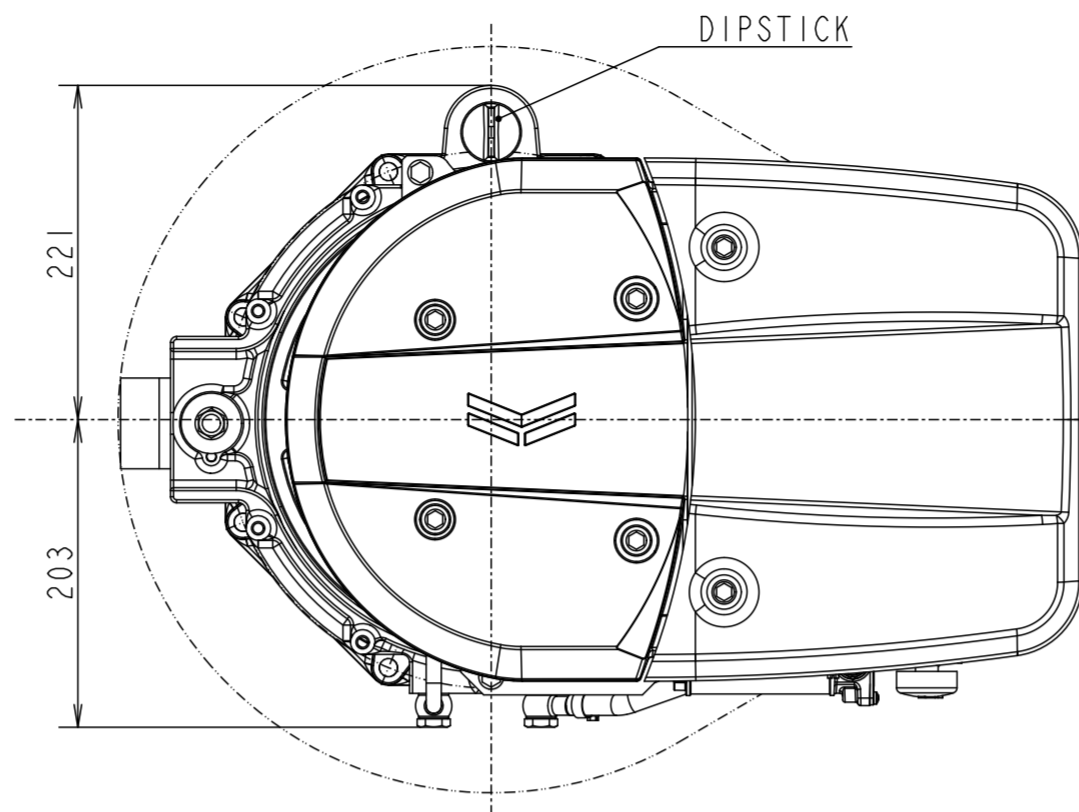
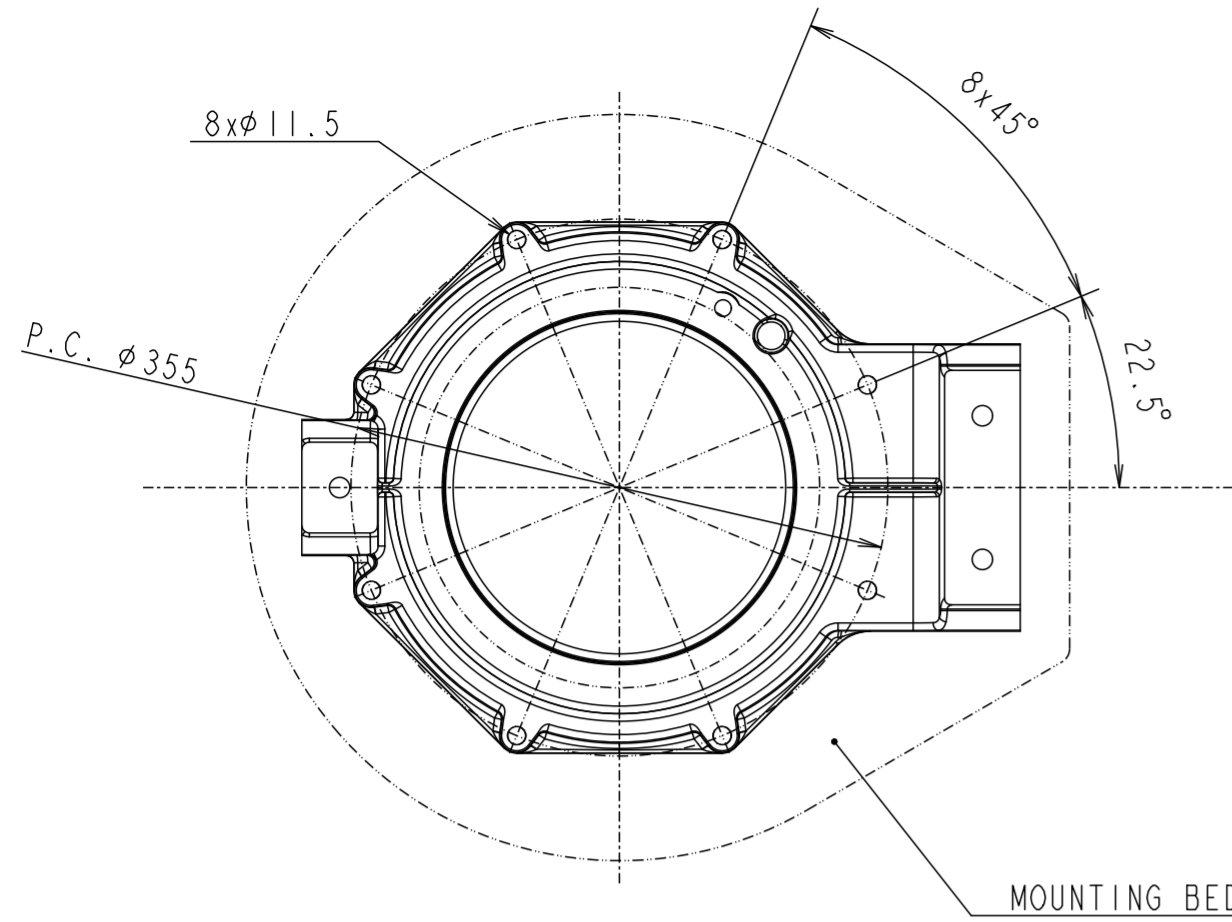
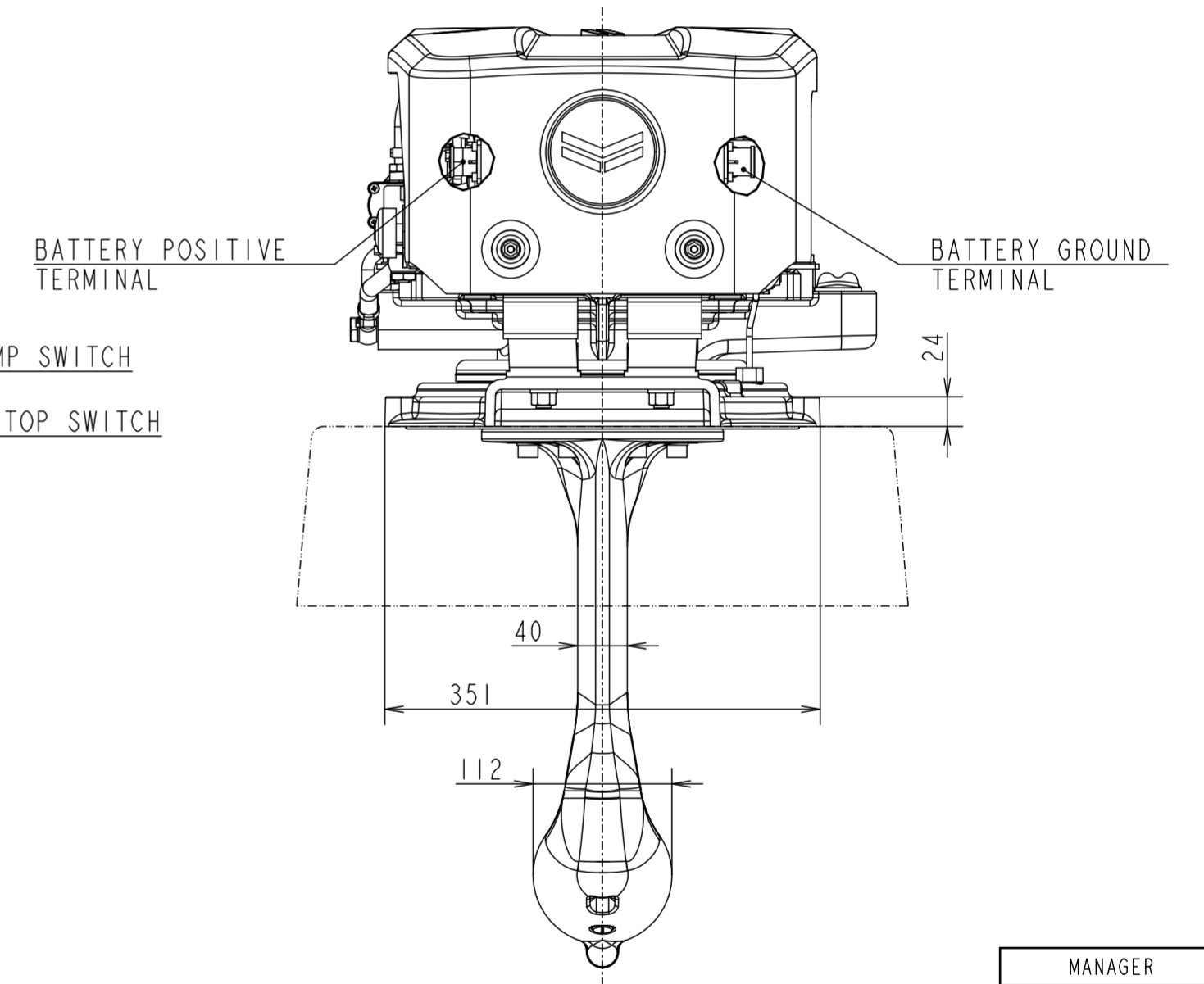
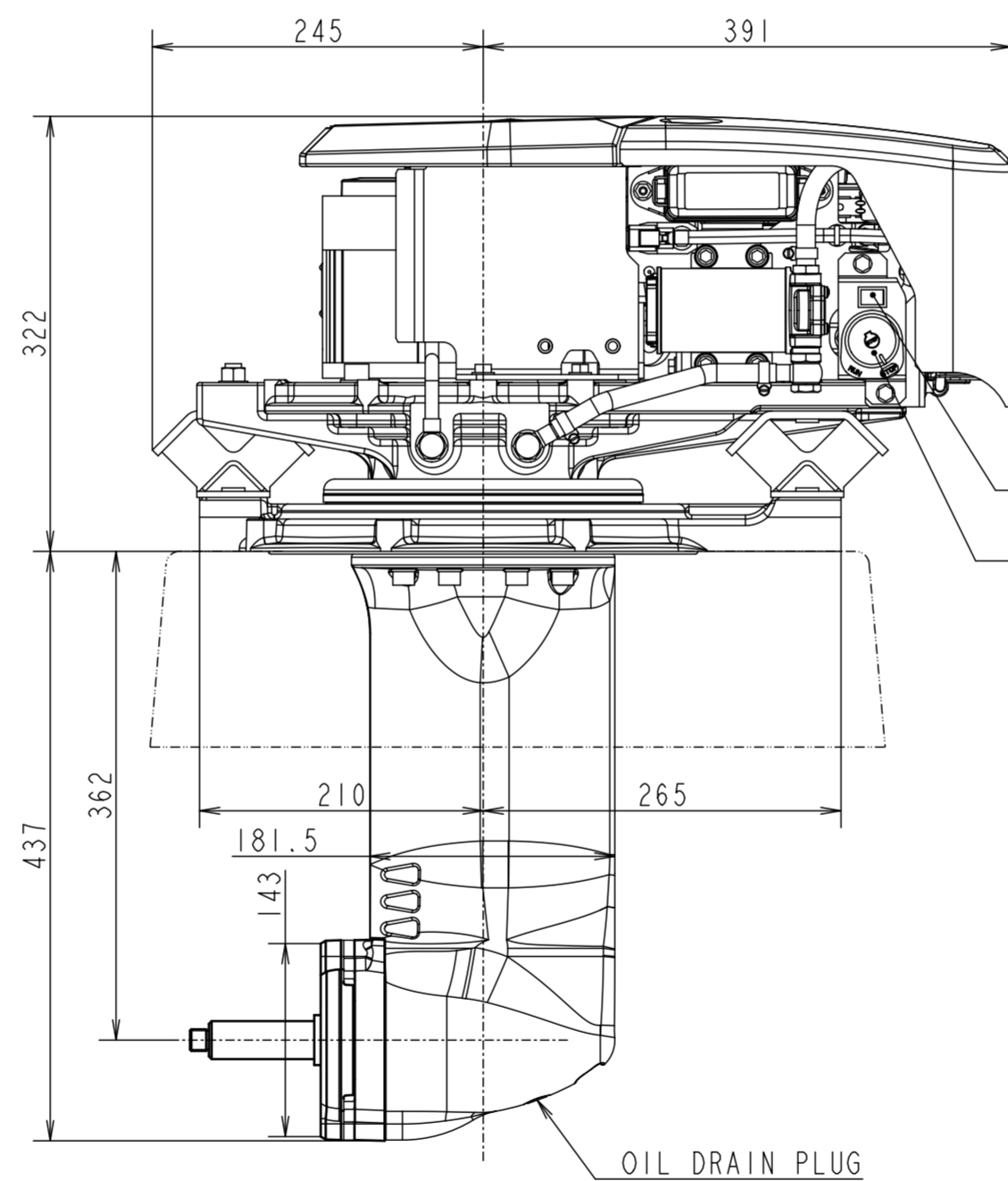
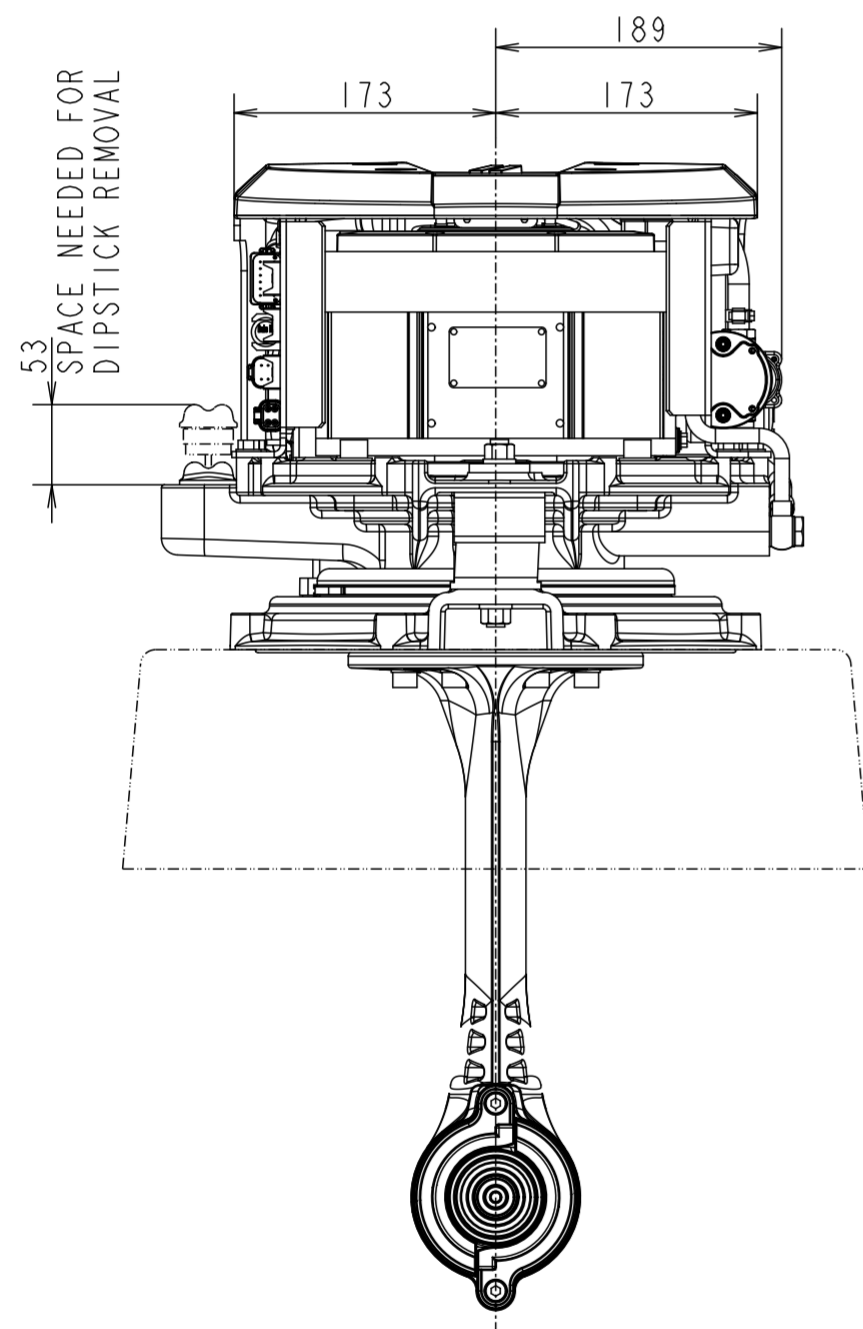

MANAGER

TECHNICAL SPECIFICATIONS		
MODEL	SDe10	SDe7
OUTPUT SHAFT POWER	10 / 2700	7 / 2700
REDUCTION RATIO	2.13	
DRY WEIGHT	70.0	
OIL TYPE	ATF	
OIL CAPACITY	3.2	

SEC. MANAGER	MODEL	SDe7	SDe10	SCALE	1:5
CHECKED	SPECIALIST	QTY		MATERIAL	
DESIGNED	DRAWN	DATE: Y.M.D	NAME	SDe7 / SDe10 OUTLINE	
	IvdB	2025.11.07			
YANMAR				CODE	B2-V5900-0020
YANMAR MARINE INTERNATIONAL B.V.				DRAW SIZE	A2

3D-CAD

NOTICE

GEOMETRICAL TOLERANCE

KIND OF TOLERANCE

SYMBOL

STRAIGHTNESS TOLERANCE

CIRCULARITY TOLERANCE

PROFILE OF LINE TOLERANCE

FLATNESS TOLERANCE

CYLINDRICITY TOLERANCE

PARALLELISM TOLERANCE

PERPENDICULARITY TOLERANCE

ANGULARITY TOLERANCE

POSITIONAL TOLERANCE

COINCIDENCE TOLERANCE

Symmetry Tolerance

Run-out

Location

Orientation

Positional Tolerance

Run-out

Location

Orientation

Positional Tolerance

Run-out

Location

Orientation