

IV. SAFETY OPERATIONS

1. After and before operations

Inspect your machine before operating. Check and repair of every unusual condition, service after using this machine.

2. Operating the paddy reaper machine

Turn off the machine before servicing or maintaining. Be sure the blade clutch lever and main clutch lever are " **Off** " position, and the shift lever on " **Neutral** " position.

3. Keep the machine in a good condition

Check your machine periodically on each harvest season to anticipate any problem when it will use. The damage problem is caused by attentiveless maintenance. So good maintenance will be very helpful to run the machine safely.

4. Driving the machine on the road.

Giving more air pressure is not necessary when it is operated on the road. Because the tire is made of zero pressure type but the speed machine will more slowly run.

V. PREPARATION

1. Fuel oil

a. Machine

Inspect the fuel oil and oil level on the machine whether insufficiently used on the flat road.

Note : The machine oil capacity is 0.6 litre type SAE-20W-50.

ATTENTION : After filling out the oil, pull the starter handle many times so it will spread out through.

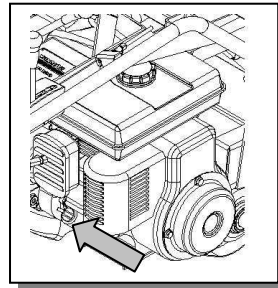

b. Paddy Reaper transmission

Transmission oil capacity is 1.1 litre type SAE-90. The sufficient oil addition is shown on the oil surface of the bevel gear in the transmission vessel.

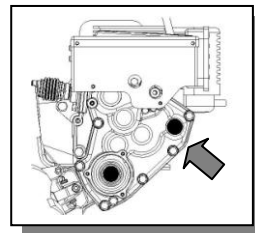

2. Lubricating oil

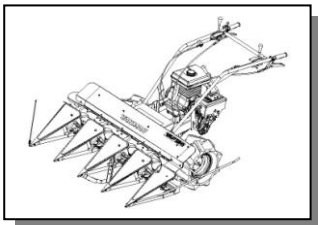

Inspect the machine oil and transmission. The oiliness causes damage gear on the other hand the excessively oil will cause the machine power decreased.

VI. MACHINE OPERATION

1. STARTING THE MACHINE

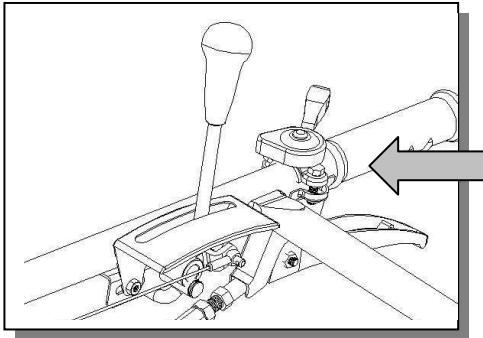
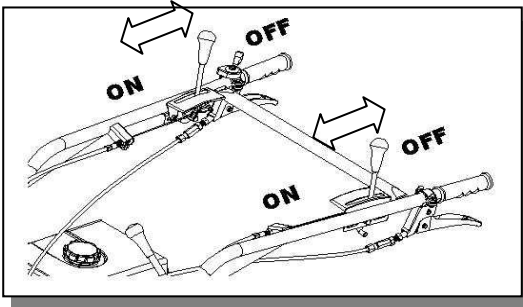

- Main clutch lever and blade clutch lever must stay to " Off " position and shift lever is " Neutral " position.
- Turn the fuel tap shift to " On " position so the fuel will spread out into the machine.
- Turn the throttle to high level position.
- Pull the handle starter strongly to start the machine then release it slowly.
- Heat up that machine for 3 ~ 5 minutes with the throttle lever is " On " position.

Attention : When the machine is difficult to start, shift the choke lever at the open position and pull the starter strongly. When it has be on, shift the choke lever at the previous position.

2. STOPPING THE MACHINE

- Pull the main clutch lever to " Off " position.
- Pull the blade clutch lever to " Off " position.
- Arrange the throttle lever on the low position.
- Switch off the machine.
- Move the fuel shift to " Close " position.

3. HOW TO DRIVE THIS MACHINE

- **Side clutch lever** is use to adjust turning machine right or left. The clutch will turn left if left clutch is pressed.

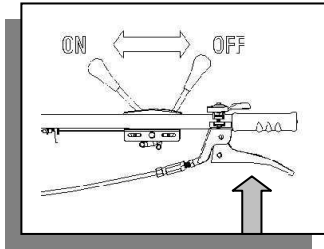

DISENGAGE

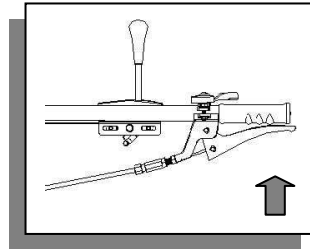

PRESSED

- **Main clutch lever** is used to run the machine. It will run if the shift pushed to " On " position and will stop if it is pulled to " Off " position.

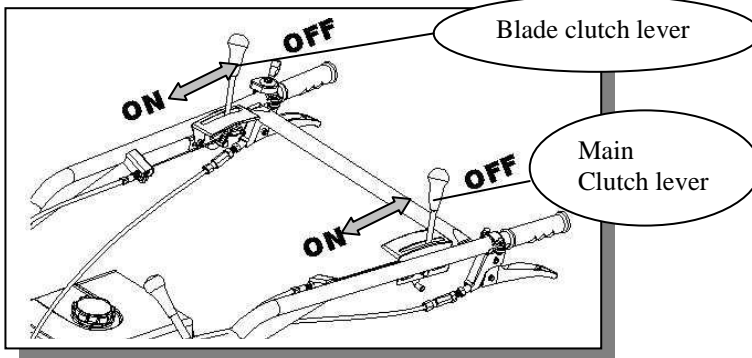

- **Blade clutch lever** is used to run the reaper if the shift is pushed to " On " position the clutch will move and stop when pulled to " Off " position.
- Shift lever is used to adjust forward, backward, neutral speed. To use the shift lever, see the position on speed indicator.

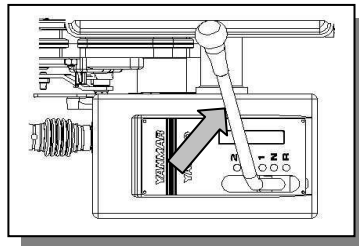

ATTENTION: Don't move the shift lever when the main clutch lever is " On " position.

Arranging speed :

- a. Pull main clutch lever to " **Off** " position, then move the shift lever on position where needed.
- b. Press the main clutch lever to " **On** " position.
- c. Arrange the throttle lever on position that wanted.

Operating the cutting blade :

- a. Set the shift lever on position wanted. (Position 1 or 2).
- b. Arrange the lever throttle to " **start** " position or high speed.
- c. Release the blade clutch lever to " **On** " position.
- d. Arrange the lever throttle to speed wanted.
- e. To run the blade clutch lever without moving. Pull the main clutch lever to " **Off** " position.
- f. Set the shift lever to " **N** " (**Netral**) position.
- g. Release the blade clutch lever to " **On** " position so it will run automatically.
- h. Arrange the throttle lever that wanted.

How to run the paddy reaper backward :

- a. Be sure the shift lever is " **Off** ".
- b. Set the shift lever to " **R** " position.
- c. Turn the lever throttle to the low position.
- d. Release the shift lever to " **On** " position.

ATTENTION : It is suggested to use slow speed in changing backward position.

How to drive on roads :



- a. The blade clutch lever is to " **Off** " position.
- b. Be sure that main clutch lever to " **Off** " position.
- c. Arrange the lever throttle on low position.
- d. Set the shift lever on position 2.
- e. Release the main clutch lever to " **On** " position.
- f. Set the lever throttle on speed needed.

ATTENTION : Periodically maintenance is an action to make the long life machine.

VII. PREPARATIONS TO REAPING WORK

1. Field and plant condition

The way of reaping paddy is depend on plant and wide field condition. Run the machine position should be opponent of the sloping plant.

Cutting and plant condition	Prostrate angle 	Stand 
The sloping plant is one way with the reaped.	X	O
The reaped is opposite of the sloping plant.	△	O
The lying plant is on the left or right cut .	O	O

O = Good △ = Good & carefull X = No recomended

2. Reaping plant specification

Type of plant	Paddy
Reaped height	06 - 30 cm
Paddy stem length	50 - 100 cm
Prostrate angle	30 - 60 degree
Paddy height	60 - 120 cm
Filed depth	< 20 cm

3. Field preparation

Reaping in the corners of fields :

Take up the space for reaper circling by hand worked reaping of enough areas for it to circle in a field.

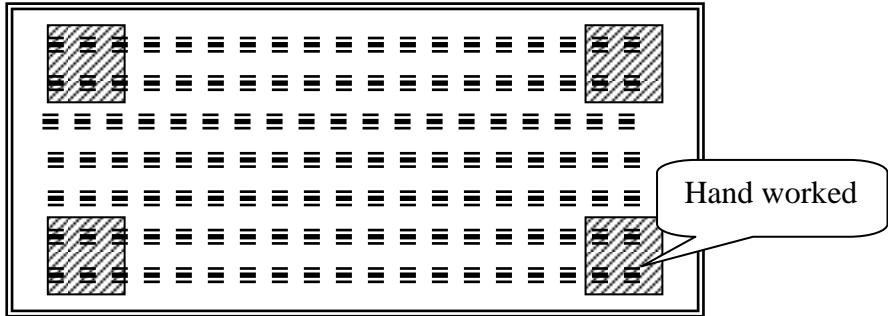

4. How to reap

There are several way to reap :

a. Counter clockwise reaping is a standardized working method in for cornered fields.

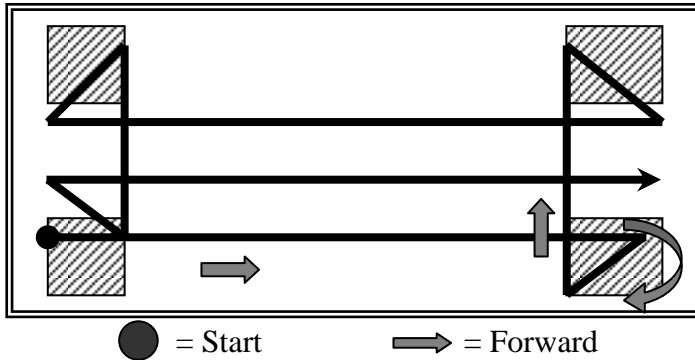

b. Return reaping is suitable for rectangular fields.

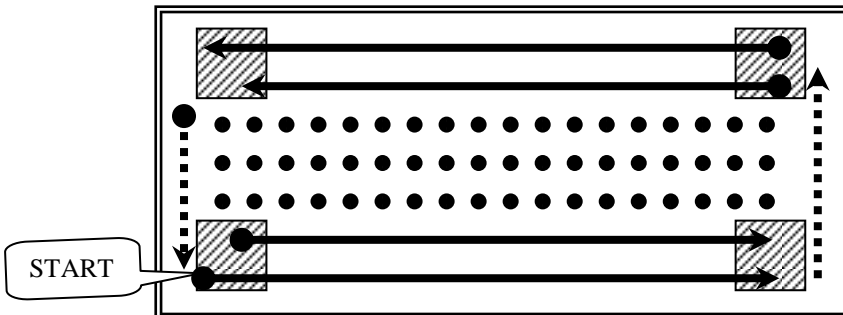

5. Change of direction

Positive changing of the direction of reaper in the limited corners of fields is to back it after making its forward movement and to move it forward again.

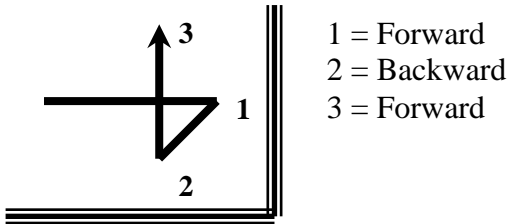

6. Reaping prostrate crops

Reaping prostrate crops may be practicable if their prostrate angles are less than 60 degree. Practise reaping of prostrate crops by lowering the extreme point areas of the machine to make the reaped height low.

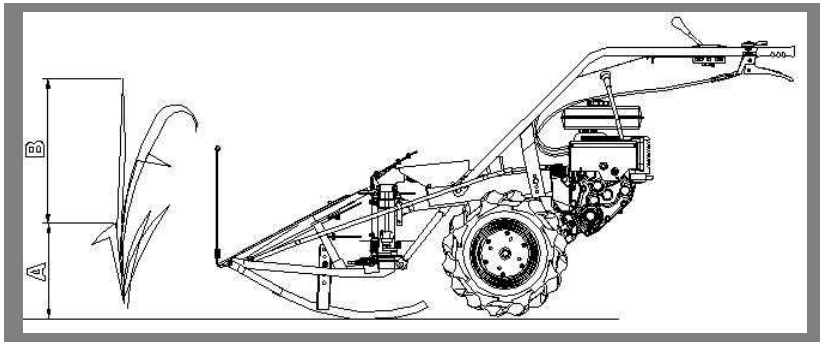

A=Reaped height

B= Length of reaped plants (ears of rice)

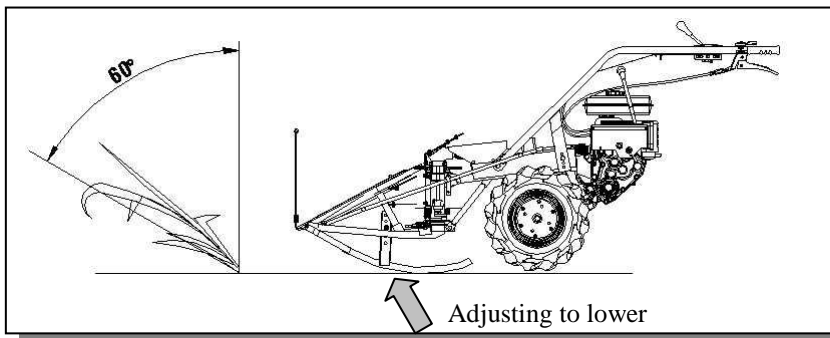

VIII. ADJUST AND FIX

a. Cable clutch

Set cable side clutch by lengthening or shortening an arranger, should have free distance $\pm 0,5 \sim 1,5$ mm the clutch is pressed.

Posisi belum di tekan

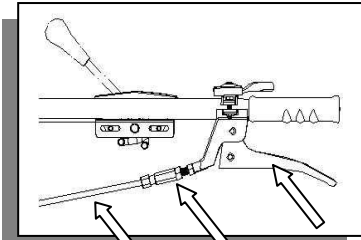

A B C

A= Cable side clutch
B= Adjusting screw
C= Lever

Posisi sesudah di tekan

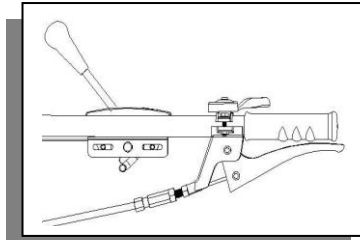

Free different side clutch
 $\pm 0.5 - 1.5$ mm

b. Reaping drive

Operating the paddy reaper machine continuously will make the reaping drive slack or loose, so inspect the nut to have $\pm 0,5 \sim 1,5$ mm of reaping drive to bolt.

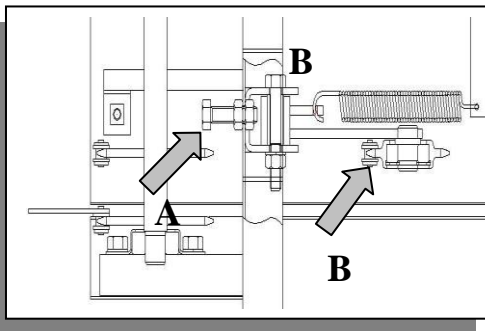

A= Adjusting bolt

B= Tension lever

c. Carrying chain

Tension given to a carrying chain, deflection must be 5 to 10 mm at the pushing point shown in a figure.

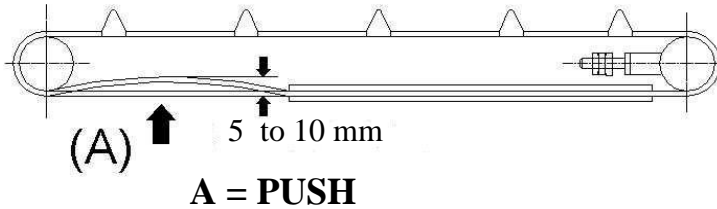

Adjustment of a carrier driving chain :

- ❑ Loosen nut 1 and nut 2 . Tighten a chain by pulling to right, then tighten the nuts.

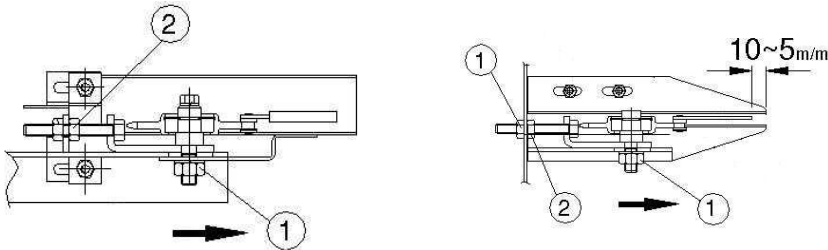

- ❑ Adjustment of carrying chain lower, loosen a nut 1 and 2 pull the chain to right. Arrange the distance of carrying chain lower with cover (cover A-B) $\pm 10 - 5$ mm.

d. Adjustment of guide rod

Inspect the clearance between a guide rod and middle plate when the lateral carrying and the releasing of crops go out of order.

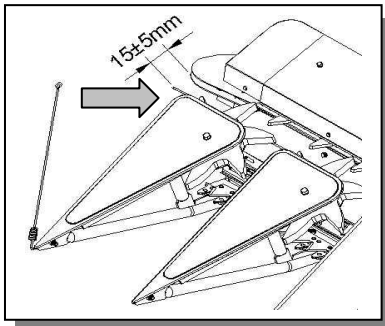

- ❑ Inspect the clearance.
- ❑ Loosen a bolt or a nut.
- ❑ Adjust the clearance and measure using a ruler so that it may be 15 \pm 5 mm.
- ❑ Assure the positive tightening of a bolt or a nut.

e. Reaping cutter

The most important of all the reaping cutter. Prepare cutters so that they may cut well at any time and lubricating oil if it is not being used.

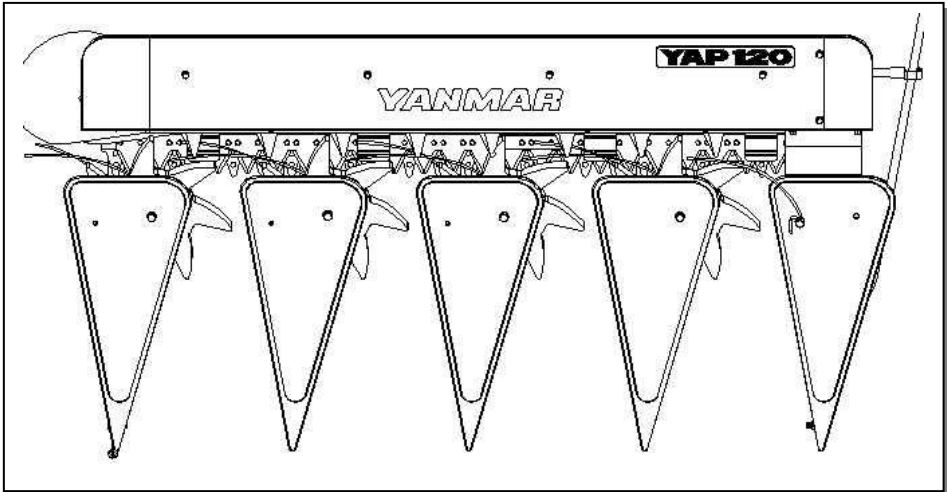

How to detach reaping cutter,

- Place a rest under reaping cutter of the machine through raising the front.

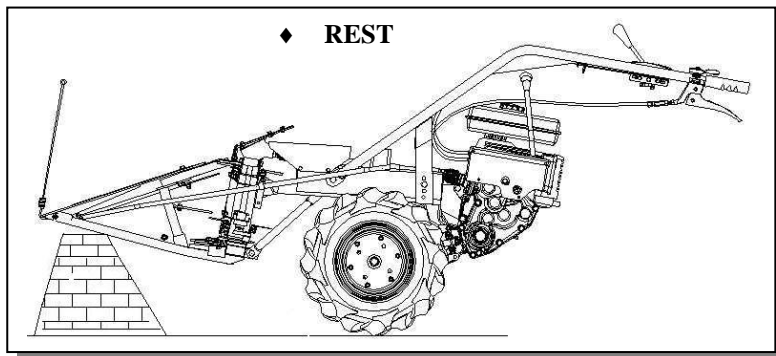

- Detach board swath lower by loosening six pieces of screws.
- Take off two pieces of bolts and nuts fixing reaping cutter.
- Reaping cutter can be taken out sideways.

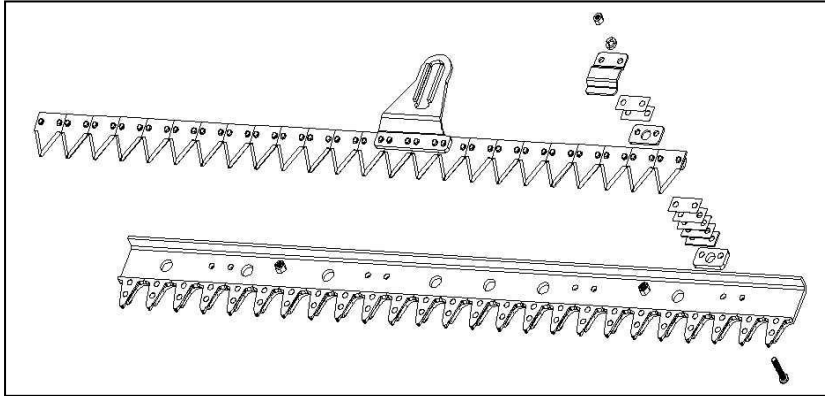

- Reaping cutter can be drawn out when the left knife clip is taken off.
- Installations must be performed in reverse order.
- Be careful, when you insert the base cutter on to roller exentric, set and tighten bolts and nut again.

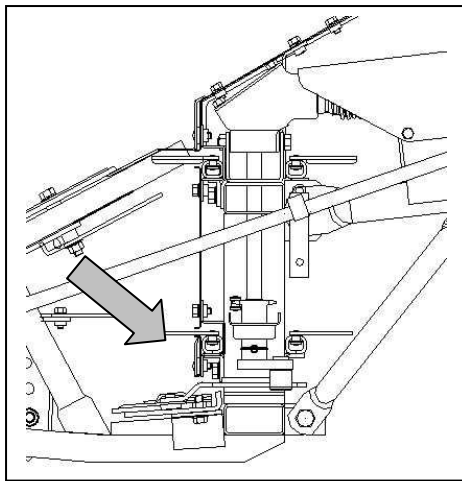

f. Cutting level settlement

Cutting height level can be arranged based on the condition of land with standard distance between 6 ~ 30 cm.

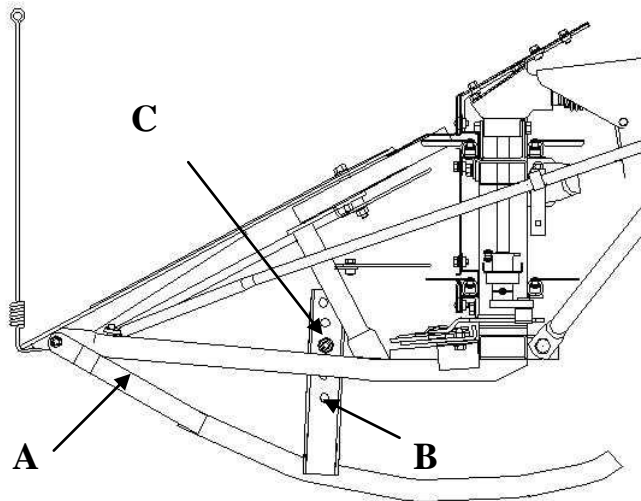

- A = Sled (SKID)
- B = Highness arranger hole
- C = Highness arranger bolt

For settling the two bolts M12x30 on the frame of cutting highness arranger. Choose one of holes position (left or right) suitable with the condition needed. By putting up or down the handle. Then settle the bolt M12x30 and tightened. Arrange highness of sled by realizing bolts and suit with the hole needed.

- A = Highness arranger plate on the handle.
- B = Highness arranger bolt.
- C = Highness arranger hole.

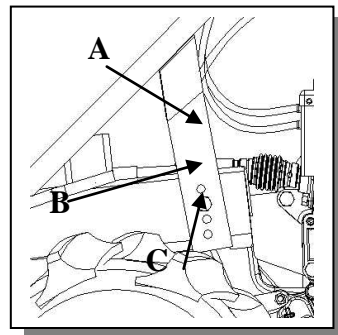

Attention :

To suit for cutting level don't ever a part from fitting plate, in order to make some suspensions. (right or left).

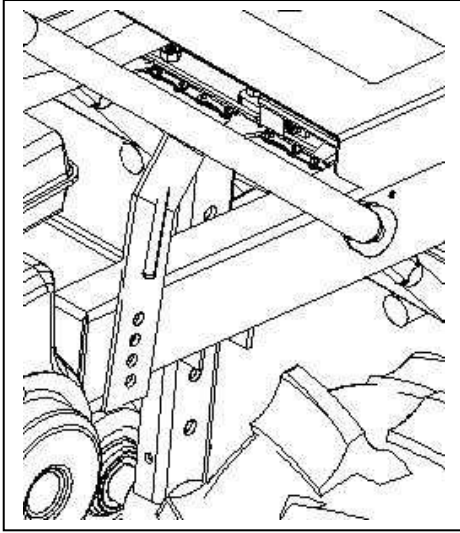

Suspension for arranging the cutting level.

g. Safety clutch

The safety clutch will work if the load of knife or chain charier is heavier, but the engine still run.

The safety clutch can be save the component of gear box.

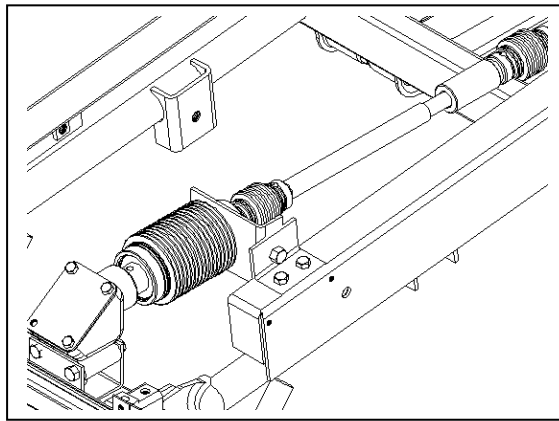

If the result of the safety clutch still less maximal, spring can be passed using:

- Open the safety rubber (A)
- Lose the hex. bolt M6 (B)
- Tighten the adjuster (C)
- If result is enough, the hex. bolt M6 is tighten again.(B)
- Lubrication the safety clutch.
- Closed the safety rubber (A)

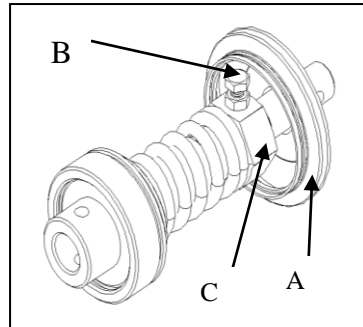

Attention:

Lubrication the safety clutch before operate

h. tire organizing

The distance of left or right tire can settled as we need. The way of organizing lift the left or right tire, give one of them a prop realize the snap pin of tire pin, then pull or push the tire in to the hole, put the tire pin and set the snap pin back.

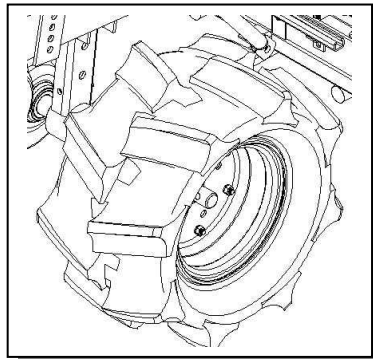

Attention : Standard spare of Yanmar for safety and comfortable use is recommended.

IX. MAINTENANCE AND INSPECTIONS

Perform lubricating, inspection, and adjustments prior to operations so that the machine may work well and stand long use.

List of lubrications, oiling, and inspections.

Lubricated areas	Daily,prior to operations	Time of exchange		Descriptions	Remark	
		The 1st	After thar			
Fuel tank	Refuel			Gasoline	3.8 liter	
Air filter	Inspect, clean	After 10 hr.	Every 50 hrs.			
Engine crank casing	Inspect, and Supply			SAE20W-50	0.6 liter	
Mission casing				SAE-90	1.1 liter	
Chain casing				Grease	0.75 liter	
Bevel case				Grease	Proper quantity	
Tension fulcrum	Inspect, Adjustment	Daily lubrications, prior to operations		SAE-90	Proper quantity	
Reaping cutters	Lubricate				SAE-90 atau SAE-30	Proper quantity
Crank Arm						
Chain drive						
Blade clutch						
Main clutch						
Carrying chain upper						
Carrying chain lower						
Blade clutch cable						

Main clutch cable	Inspect, Adjustment			
Adjuster	Inspect, Adjustment			
Looseness of bolts and nuts	Inspect, Adjustment			Inspect, tighten
Knife head	Inspect			Grinding

PART LIST