



YANMAR

Vi027-7

MINI EXCAVATOR



Operating weight

2 650 kg (Canopy) / 2 745 kg (Cabin)

Engine

3TNV80F - ZXKBVA

Digging force (arm)

16.5 / 13.6 kN (long arm)

Digging force (bucket)

21.4 kN

THE URBAN ALLY FOR ANY JOBSITE

PERFORMANCE

Achieves digging force up to 21.4 kN (bucket) and 13,6 kN on long arm. The traction force reaches 23.5 kN in 1st speed for unmatched ground engagement.

OPERATOR SPACE

The spacious cabin features a large door, large windows, and a wide display for optimal comfort.

POWER

Delivers 18.4 kW at 2400 rpm, powered by a new-generation electronically controlled engine designed to maximize fuel efficiency. Integrated Eco Mode, Auto Idle (standard) and Auto Stop (option) functions further optimize performance.

COMPACTNESS



Features a zero tail swing design, enabling smooth maneuvering in the tightest spaces without compromising stability — and delivering added safety and peace of mind on every jobsite.

VERSATILITY

Enables quick attachment changes with optimized front stability for efficient working. Supports main connection systems, allowing work with a wide range of attachments.



THE URBAN ALLY FOR ANY JOBSITE

-  Compact power meets zero-tail precision.
-  The Vi027-7 operates safely close to buildings, sidewalks and traffic—perfect for urban foundations, landscaping, and confined worksites.
-  Combining narrow undercarriage, excellent visibility, and VIPPs hydraulic smoothness, this ultra-compact powerhouse delivers fast, simultaneous movements even while traveling—without compromising on power.



SMALL FRAME, FULL POWER

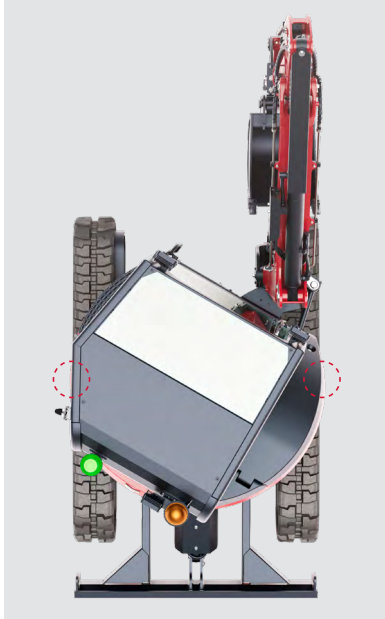

DESIGNED FOR DENSE ENVIRONMENTS

Purpose-built for demanding **urban applications**, the Vi027-7 combines compact dimensions with **confident performance on congested jobsites**.

With an overall width of just 1,500 mm including cab and rubber tracks and a transport weight of 2,565 kg, it easily accesses restricted areas while maintaining stability and control.

The wide boom swing range (75° left / 60° right) further enhances manoeuvrability, allowing operators to **work safely around pedestrians and obstacles in busy environments**.

The machine is well suited to urban construction, tight landscaping environments and small building or renovation projects where space is limited and awareness of surroundings is essential.

ZERO-TAIL SWING

Its true zero tail swing configuration enables operators to work safely alongside buildings, sidewalks and traffic, drastically limiting the risk of contact or damage.

LIGHT ON THE GROUND, STRONG AT WORK

Thanks to its compact structure and optimised weight distribution, the Vi027-7 delivers **impressive stability** while remaining **gentle on sensitive surfaces**. Low ground pressure allows confident operation on soft terrain, landscaped areas and renovation sites where surface protection is critical. Whether working on slopes, trenching for utilities or navigating finished environments, the machine combines **agility** with dependable **control** for safe, efficient operation.

COMPACT SIZE, FULL-SCALE PERFORMANCE

Despite its reduced footprint, the Vi027-7 delivers digging and hydraulic performance that meets demanding jobsite expectations. With breakout force up to **21.4 kN** and a maximum digging reach of 4.8m, it tackles **deep excavations and tough materials** across urban construction, landscaping and small-scale building projects.



TRANSPORT-READY MOBILITY

The Vi027 is perfect for professionals who move between jobsites daily and rental companies seeking maximum fleet flexibility. With the machine, quick coupler and two-bucket standard attachment package **staying within the 3.5-tonne transport regulation**, operators can use standard trailers and private vehicles without requiring commercial licenses. Four integrated tie-down points on the lower frame ensure fast, secure loading and unloading. This transport efficiency translates directly into lower operating costs per job, reduced downtime between sites, and simplified logistics—making the Vi027 an **ideal choice for contractors and rental fleets maximizing utilization across multiple projects**.



OPERATOR-FOCUSED DESIGN



COMFORT AND VISIBILITY FOR ALL-DAY PRODUCTIVITY

The spacious cabin features a **wide 425mm entrance** for easy access, **large windows** providing excellent visibility of the work area, and a **4.3" LCD display**. Ergonomic controls and generous interior space reduce operator fatigue during long shifts, allowing sustained focus and precision throughout the day. Clear sightlines and intuitive layout keep operators confident and in control, even in demanding urban environments.

RESPONSIVE PERFORMANCE AT YOUR COMMAND

Powered by a **proven 3TNV80F Stage V engine** and paired with the ViPPS hydraulic system operating at 210 bar maximum pressure, the machine ensures fast cycle times and controlled movements. The double variable displacement piston pump (2 x 32.4 l/min) provides responsive hydraulics for **smooth, precise operations** even during intensive tasks—combining speed, accuracy and efficiency in a compact package.

INSTANT CONFIDENCE, FROM DAY ONE

Designed with simplicity in mind, the controls are **intuitive enough for any operator to get productive** from the very first shift. And for those who need an extra hand, Yanmar Scan delivers **instant access to key machine information** – just scan the QR code on the machine with your smartphone. Essential settings, maintenance guidance, and operational tips: all at your fingertips, on the spot. A smart companion to the official manual, helping every operator hit the ground running.

SIMPLIFIED MAINTENANCE, MAXIMUM UPTIME

MAINTENANCE MADE EFFORTLESS

Wide-opening covers give immediate **ground-level access to all critical components** – engine, filters, battery, radiator, hydraulic fluid – no tools, no gymnastics. Daily checks take minutes, not hours, keeping downtime where it belongs: at zero. Less time under the hood means more time on the job.

OPTIMIZED SERVICE SCHEDULE, MAXIMUM MACHINE AVAILABILITY

With a first service between 50 and 80 hours, followed by extended maintenance intervals, **servicing is predictable and easy to plan**. Engine oil and main filters are replaced every 500 hours, fuel filters every 250 hours, and coolant only every 2,000 hours – reducing workshop visits and operating costs. Clearly structured service points and long replacement intervals mean less downtime, lower total cost of ownership, and more productive hours on site.

AN ENGINE YOU CAN COUNT ON - REPLACEMENT PARTS READILY AVAILABLE

Yanmar engines are world-renowned for their **robustness, fuel efficiency, and longevity** – built to keep running shift after shift, year after year. When a part is needed, Yanmar's extensive dealer network ensures fast availability across the region, so you're never left waiting. Genuine Yanmar parts, sourced locally: because reliability doesn't stop at the engine.



DIMENSIONS

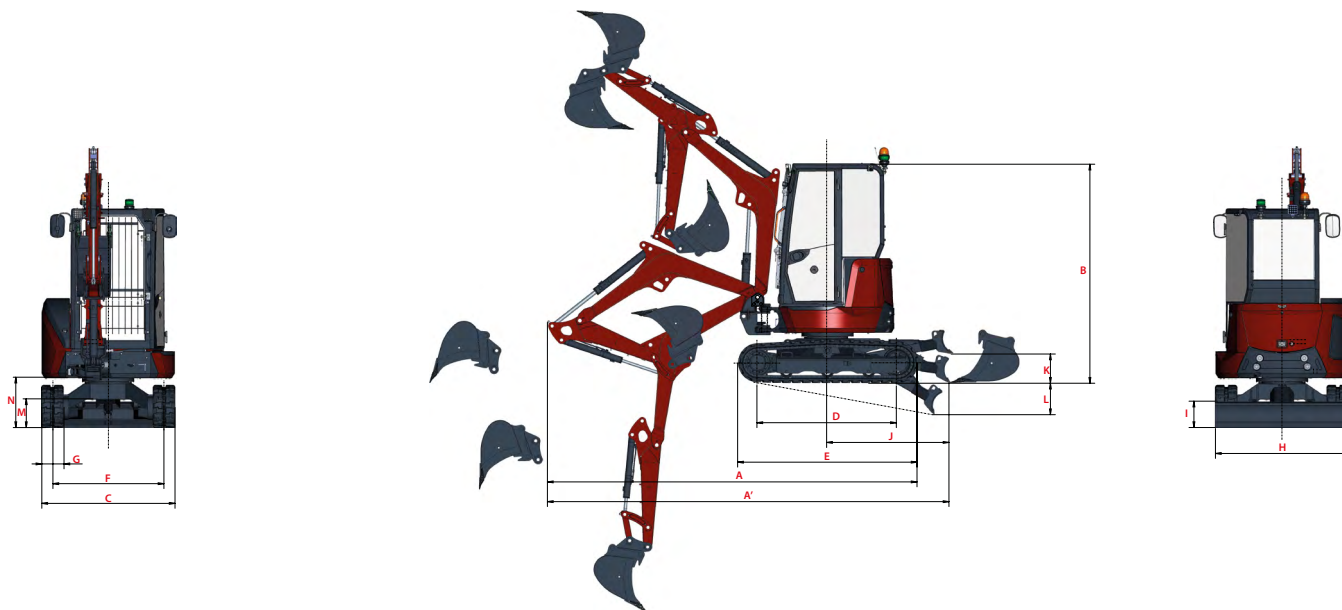

A Overall length	4165 / 4180* mm	G Track width	250 / 300** mm
A' Overall length with blade at the back	4525 / 4540* mm	H Overall blade width	1500 mm
B Overall height	2470 / 2465** mm	I Overall blade height	300 mm
C Overall width	1500 / 1550** mm	J Blade distance	1380 mm
D Length of track on ground	1570 mm	K Max. lifting height above the ground	330 mm
E Undercarriage length	2020 mm	L Max. lowering depth from the ground	355 mm
F Lane	1250 mm	M Minimum ground clearance	325 mm
		N Minimum ground clearance under upper frame	555 mm

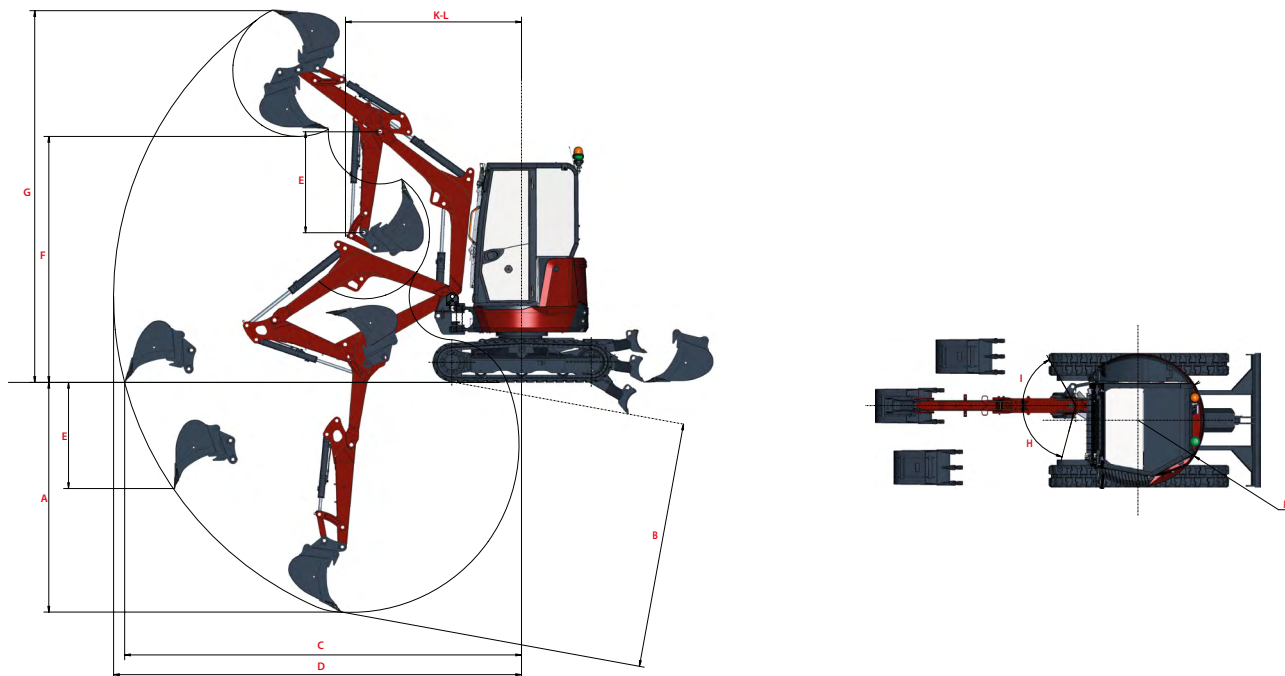

A Max. digging depth - Blade lifted	2590 / 2835* mm	H Boom swinging base to left	75°
B Max. digging depth - Blade lowered	2775 / 3025* mm	I Boom swinging base to right	60°
C Max. digging reach on ground	4470 / 4720* mm	J Arm length	1150 / 1400* mm
D Max. digging reach	4595 / 4835* mm	K Front turning radius	1985 / 2025* mm
E Max. vertical wall	1195 / 1400* mm	L Front turning radius with boom swing	1105 / 1115* mm
F Max. unloading height	2770 / 2930* mm	M Rear turning radius	750 mm
G Max. cutting height	4190 / 4345* mm	M' Rear turning radius with additional counterweight	825 mm

Short arm/ long arm* ** Extended tracks *** Canopy / Cabin

LIFTING CAPACITY



Tipping load, rating over front



Tipping load, rating over side 90°

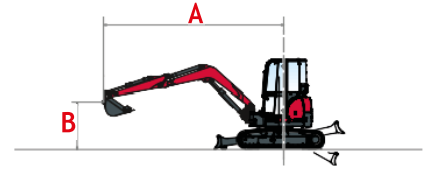

Long arm, additional counterweight

Canopy												
Blade on ground/Blade above ground												
A	Max		3,5 m		3 m		2,5 m		2 m		1,5 m	
B	⇐	⇓	⇐	⇓	⇐	⇓	⇐	⇓	⇐	⇓	⇐	⇓
3 m	405/405	*485/485	/	/	*455/455	*455/455	/	/	/	/	/	/
2,5 m	330/330	490/415	365/365	*475/475	*460/460	*460/460	/	/	/	/	/	/
2 m	300/300	495/375	360/360	*490/490	*505/505	*505/505	/	/	/	/	/	/
1,5 m	285/285	500/355	355/355	530/445	455/455	*580/580	*665/665	*665/665	/	/	/	/
1 m	280/280	520/350	345/345	575/435	435/435	665/550	575/575	*825/825	805/805	*1180/1180	/	/
0 m	285/285	545/355	330/330	635/420	410/410	785/525	535/535	1025/690	740/740	1480/985	1195/1195	2455/1700
-1 m	345/345	570/435	/	/	405/405	725/520	525/525	955/685	740/740	1310/985	1210/1210	2000/1720
-1,5 m	435/435	*595/595	/	/	/	/	535/535	*780/780	750/750	*1070/1070	1230/1230	*1575/1575

Cabin												
Blade on ground/Blade above ground												
A	Max		3,5 m		3 m		2,5 m		2 m		1,5 m	
B	⇐	⇓	⇐	⇓	⇐	⇓	⇐	⇓	⇐	⇓	⇐	⇓
3 m	485/485	*485/485	/	/	*455/455	*455/455	/	/	/	/	/	/
2,5 m	345/345	490/490	380/380	*475/475	*460/460	*460/460	/	/	/	/	/	/
2 m	310/310	495/390	375/375	*490/490	*505/505	*505/505	/	/	/	/	/	/
1,5 m	295/295	500/370	370/370	530/530	470/470	*580/580	*665/665	*665/665	/	/	/	/
1 m	290/290	520/365	360/360	575/450	455/455	665/665	595/595	*825/825	830/830	*1180/1180	/	/
0 m	295/295	545/375	345/345	635/435	430/430	785/545	555/555	1025/720	770/770	1480/1025	1240/1240	2455/1770
-1 m	360/360	570/455	/	/	425/425	725/540	550/550	955/710	770/770	1310/1025	1255/1255	2000/2000
-1,5 m	455/455	*595/595	/	/	/	/	555/555	*780/780	780/780	*1070/1070	1275/1275	*1575/1575

Long arm												
Canopy												
Blade on ground/Blade above ground												
A	Max		3,5 m		3 m		2,5 m		2 m		1,5 m	
B	⇐	⇓	⇐	⇓	⇐	⇓	⇐	⇓	⇐	⇓	⇐	⇓
3 m	370/370	*485/485	/	/	*455/455	*455/455	/	/	/	/	/	/
2,5 m	300/300	490/375	330/330	*475/475	*460/460	*460/460	/	/	/	/	/	/
2 m	270/270	495/340	330/330	*490/410	*425/425	*505/505	/	/	/	/	/	/
1,5 m	255/255	500/320	320/320	530/405	410/410	*580/580	*550/550	*665/665	/	/	/	/
1 m	250/250	520/315	310/310	575/395	395/395	665/505	520/520	825/670	730/730	*1180/965	/	/
0 m	250/250	545/320	295/295	635/375	370/370	785/475	480/480	1025/625	670/670	1480/895	1080/1080	2455/1550
-1 m	310/310	570/395	/	/	365/365	725/470	475/475	955/620	670/670	1310/895	1095/1095	2000/1570
-1,5 m	390/390	*595/505	/	/	/	/	485/485	*780/630	680/680	*1070/910	1115/1115	*1575/1575

Cabin												
Blade on ground/Blade above ground												
A	Max		3,5 m		3 m		2,5 m		2 m		1,5 m	
B	⇐	⇓	⇐	⇓	⇐	⇓	⇐	⇓	⇐	⇓	⇐	⇓
3 m	385/385	*485/485	/	/	*455/455	*455/455	/	/	/	/	/	/
2,5 m	310/310	490/390	345/345	*475/475	*460/460	*460/460	/	/	/	/	/	/
2 m	280/280	495/355	340/340	*495/495	*505/505	*505/505	/	/	/	/	/	/
1,5 m	265/265	500/340	335/335	530/420	430/430	*580/580	*570/570	*665/665	/	/	/	/
1 m	260/260	520/335	325/325	575/410	410/410	665/525	540/540	*825/700	760/760	*1180/1005	/	/
0 m	265/265	545/340	310/310	635/395	385/385	785/495	500/500	1025/655	700/700	1480/935	1125/1125	2455/1620
-1 m	320/320	570/410	/	/	380/380	725/490	495/495	955/650	695/695	1310/935	1140/1140	2000/1635
-1,5 m	410/410	*595/595	/	/	/	/	505/505	*785/655	710/710	*1070/1070	1160/1160	*1575/1575

LIFTING CAPACITY

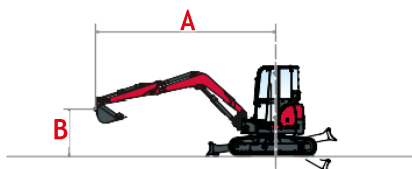

Tipping load, rating over front



Tipping load, rating over side 90°

Standard arm, additional counterweight

Canopy												
Blade on ground/Blade above ground												
A	Max		3,5 m		3 m		2,5 m		2 m		1,5 m	
B												
3 m	475/475	*550/550	/	/	*475/475	*550/550	/	/	/	/	/	/
2,5 m	385/385	550/550	/	/	*535/535	*535/535	/	/	/	/	/	/
2 m	345/345	550/430	365/365	*550/450	*465/465	*575/575	625/625	625/625	/	/	/	/
1,5 m	310/310	555/390	355/355	580/445	455/455	*645/645	*600/600	*765/765	845/845	1025/1025	/	/
1 m	310/310	570/385	350/350	615/435	440/440	720/555	570/570	*910/730	/	/	/	/
0 m	315/315	585/395	340/340	645/425	420/420	805/530	540/540	1050/695	750/750	1480/995	/	/
-1 m	405/405	620/510	/	/	420/420	665/535	540/540	900/700	760/760	1210/1005	1240/1240	1745/1745
-1,5 m	575/575	*575/575	/	/	/	/	635/635	*635/635	895/895	*895/895	1240/1240	*1240/1240

Cabin												
Blade on ground/Blade above ground												
A	Max		3,5 m		3 m		2,5 m		2 m		1,5 m	
B												
3 m	550/550	*550/550	/	/	*550/550	*550/550	/	/	/	/	/	/
2,5 m	395/395	550/550	/	/	*535/535	*535/535	/	/	/	/	/	/
2 m	360/360	550/450	375/375	*550/470	*480/480	*575/575	625/625	625/625	/	/	/	/
1,5 m	325/325	555/405	370/370	580/465	470/470	*645/645	*620/620	*765/765	870/870	1025/1025	/	/
1 m	320/320	570/400	365/365	615/455	455/455	720/575	595/595	*915/760	/	/	/	/
0 m	325/325	585/410	350/350	645/445	435/435	805/555	565/565	1050/725	780/780	1480/1035	/	/
-1 m	420/420	620/530	/	/	435/435	665/555	565/565	900/725	790/790	1210/1210	1285/1285	1745/1745
-1,5 m	575/575	*575/575	/	/	/	/	635/635	*635/635	895/895	*895/895	1240/1240	*1240/1240

Standard arm

Canopy												
Blade on ground/Blade above ground												
A	Max		3,5 m		3 m		2,5 m		2 m		1,5 m	
B												
3 m	430/430	*550/550	/	/	*430/430	*550/550	/	/	/	/	/	/
2,5 m	345/345	550/435	/	/	*430/430	*535/535	/	/	/	/	/	/
2 m	310/310	550/390	330/330	*550/410	*425/425	*575/575	625/625	625/625	/	/	/	/
1,5 m	280/280	555/355	320/320	580/405	410/410	*645/520	*545/545	*765/765	770/770	1025/1025	/	/
1 m	275/275	570/350	315/315	615/395	395/395	720/505	520/520	*915/665	/	/	/	/
0 m	280/280	585/355	305/305	645/385	375/375	805/480	490/490	1050/635	680/680	1480/905	/	/
-1 m	360/360	620/460	/	/	380/380	665/485	490/490	900/635	685/685	1210/915	1125/1125	1745/1745
-1,5 m	475/475	*575/575	/	/	/	/	505/505	*635/635	705/705	*895/895	1240/1240	*1240/1240

Cabin												
Blade on ground/Blade above ground												
A	Max		3,5 m		3 m		2,5 m		2 m		1,5 m	
B												
3 m	450/450	*550/550	/	/	*450/450	*550/550	/	/	/	/	/	/
2,5 m	360/360	*550/455	/	/	*450/450	*535/535	/	/	/	/	/	/
2 m	325/325	*550/410	340/340	550/430	*440/440	*575/575	625/625	625/625	/	/	/	/
1,5 m	295/295	*555/370	335/335	580/425	*430/430	*645/540	565/565	765/765	800/800	1025/1025	/	/
1 m	290/290	*570/365	330/330	615/415	*415/415	*720/525	540/540	915/695	/	/	/	/
0 m	295/295	*585/375	315/315	645/405	*395/395	*805/505	510/510	1050/660	710/710	1480/945	/	/
-1 m	380/380	*620/485	/	/	*395/395	*665/505	510/510	900/665	715/715	1210/955	1170/1170	1745/1745
-1,5 m	575/575	*575/575	/	/	/	/	525/525	635/635	730/730	895/895	1240/1240	1240/1240

[The data in this table represents the lifting capacity in accordance with IOS 10567. They do not include the weight of the bucket and correspond to 75% of the maximum static tipping load of the 87% of the hydraulic lifting capacity. Data marked with * are the hydraulic limits of the lifting force.]

SPECIFICATIONS

[WEIGHT +/- 2% (EN STANDARDS)]

	Weight	Ground pressure	Weight	Ground pressure
Operating weight (rubber/steel tracks)	2 745/2 845 kg	0.32/0.33 kgf/cm ²	2 650/2 755 kg	0.31/0.32 kgf/cm ²
Transport weight (rubber/steel tracks)	2 565/ 2 665 kg	0.30/0.31 kgf/cm ²	2 470 / 2 575 kg	0.29/0.30 kgf/cm ²
With additional counterweight	+ 90 kg	-	+ 90 kg	-

[MOTOR]

Type	3TNV80F-ZXKBVA
Fuel	Diesel
Regulation	Stage V
Net power	17.7 kW at 2400 rpm
Gross power	18.4 kW at 2400 rpm
Displacement	1.267 liters
Maximum torque	74.5 Nm (1900 +/- 100 rpm)
Cooling	Water-cooling
Starter	12 V - 1.4 kW
Battery	12 V - 55 Ah
Alternator	12 V - 55 A

[HYDRAULIC SYSTEM]

Maximum pressure	210 bar	PTO Pressure Flow	 Oil flow decreases as the pressure increases
1 gear pump	2 X 32.4 l/min		
		PTO1	0 – 170 bar / 54.2 - 26.1 l/min
		PTO2	0 – 180 bar / 33.6 – 21.1 l/min

[PERFORMANCE]

Travel speed	2.5 / 4.4 km/h
Rotation speed	9.7 rpm
Digging force (arm)	16.5 kN / 13.6 kN with long arm
Digging force (bucket)	21.4 kN
Traction force	23.5 kN / 12.1 kN*
Gradeability	30°
Noise level (2000/14/CE & 2005/88/CE)	LwA: dBA/LpA: dBA

[UNDERCARRIAGE]

Number of slide shoe plate	1
Number of bottom rollers	3
Track tensioning system	Grease adjuster

[CAPACITIES]

Fuel tank	39 l
Coolant	4,1 l
Engine oil	3,4 l (max)
Hydraulic circuit (including hydraulic tank)	49 l
Hydraulic tank	32 l

[MAINTENANCE FREQUENCY]

[Change engine oil and filter: 50 hours (1st) / 500 hours (2nd)] [Change fuel filter: 50 h (1st) / 250 h (2nd)]
 [Change hydraulic oil: 50 h (1st) / 500 h (2nd)] [Change hydraulic filter: 50 h (1st) / 500h (2nd)]
 [Change cooling fluid: 2000 hours]

EQUIPMENT

[STANDARD EQUIPMENT]

PERFORMANCE

3TNV80F Yanmar EU compliant stage V diesel engine | Direct injection | VIPPS Hydraulic system (VIPPS Progressive 3 Pump System) | AUX1 proportional hydraulic line with control on joystick | Automatic kick down (AKD) travel motors (std.) | ECO mode I Auto-idling system | Long arm (1400 mm)

COMFORT & EASE OF USE

4.3" LCD Interface | Standard mechanical suspension seat, adjustable, vinyl coat (canopy) or textile coat (cabin) | Adjustable wrist support | Foot rests | Wide travel pedals | Windshield in 2 parts (retractable upper part) | Double sliding right side window | Transparent upper front part | Wipers | Windshield washer | Automatic ceiling lamp | 2xUSB charging ports | Storage boxes | Lockable document storage | Cup holder | heating (cabin) | Quick connectors on battery terminal

SAFETY AND DURABILITY

Rear view camera on main LCD display | Safety valves on blade, boom, and arm cylinder with integrated overload warning | Handrails | Safety lever | Safety belt | Hammer for evacuation | Travel beep | Anchor points | Blade cylinder supply hose into two parts | Hoses protected by abrasion resistant sleeves & internal routing | Locking covers |

MISCELLANEOUS

Fuel gauge | Tool kit | Grease pump | Fuel filter with indication light water separator in display.

[OPTIONAL EQUIPMENT]

EQUIPMENT AND PERFORMANCE

Special paint | Additional counterweight | 2nd auxiliary circuit with proportional control | 1/2 circuit | Bio oil | 2 LED head lights on the front of the machine | flat face hydraulic quick connector AUX1 and AUX2 | Independent Powertilt supply line | 1 LED light + beacon to the rear of the machine | Auto stop.

COMFORT AND EASE OF USE

Premium mechanical suspension seat heated (opt.) | Radio FM/ DAB | Centralised greasing | Smart phone holder

SECURITY AND DURABILITY

GPS track unit (TU700I Anti-theft device (Key/Keypad/ LCD pincode) | Travel alarm white noise | Smart Assist Remote (SAR) Telematics | FOPS | front operator protection for cabin

[ATTACHMENTS]

Yanmar gives you the attachment that fit your needs and match the safety standards in force in your country: mechanical quick coupler, hydraulic quick coupler, ditching bucket, swinging bucket, backhoe bucket, hydraulic breaker...



YANMAR



Yanmar Compact Equipment EMEA

GB_Vi027-7_0426



www.yanmar.com

BUILDING
WITH YOU

Printed in France – Materials and specifications are subject to change from the manufacturer without notice – Please contact your local Yanmar Compact Equipment EMEA dealer for further information.